

# WORLD MECHANICAL CONTRACTING INC.

## INDUSTRIAL & COMMERCIAL

4325 County Rd 42, Unit 6. Windsor, Ontario, N9A 6J3  
PH: (519) 250-9782, Fax: (519) 250-5734  
wmci@bellnet.ca  
www.worldmechcontractor.ca

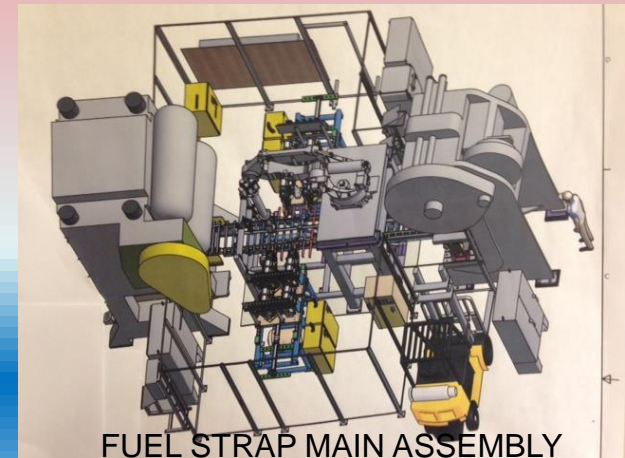
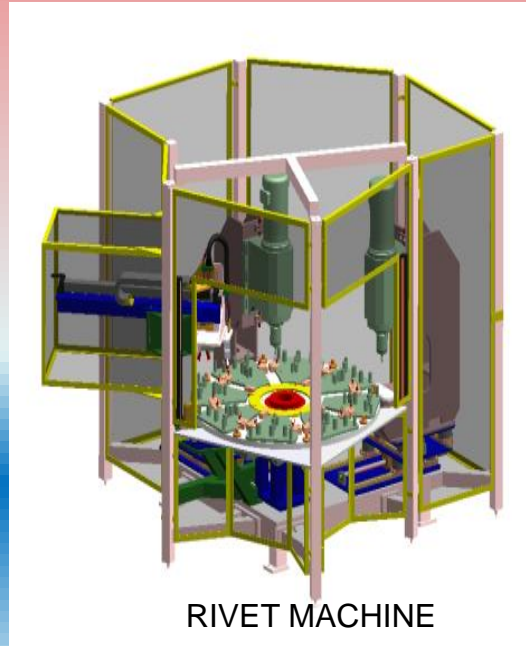
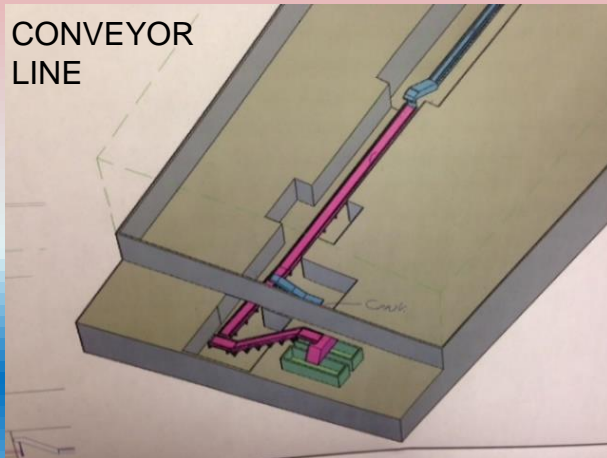

# WORLD MECHANICAL CONTRACTING INC.

## COMPANY PROFILE



World Mechanical Contracting Inc.

- Supplies complete turn-key solutions for most manufacturing environments. Whether your needs are electrical, mechanical, pneumatic, hydraulic, or controls, we have the expertise to implement effective solutions for your manufacturing problems.
- Specialized in design, fabrication and installation of highly sophisticated production and test machines and material handling systems.
- Provides the necessary resources to implement robust integrated solutions for manufacturing environments.

## COLLABORATION



### KEY BENEFIT

- Up-to-date Project Information
- Complete Project / Program History
- Universal Project Visibility
- Process Standardization
- Enhanced Accountability
- Reduction in time spent collecting and managing information

# WORLD MECHANICAL CONTRACTING INC.

## QUALITY POLICY



- ❖ World Mechanical Contracting management and employees are committed to constantly meeting or exceeding our customer's requirements in order to maximize customer satisfaction.
- ❖ This will be achieved by ensuring quality management principles are used effectively throughout all processes within the organization. We will establish effective partnership with our suppliers to ensure that purchased goods and services meet our requirements.
- ❖ World Mechanical Contracting, management and all employees are committed to continuous improvement. All processes are analyzed and their effectiveness challenged in order to improve current practices.

# WORLD MECHANICAL CONTRACTING INC.

## QUALITY POLICY



**World Mechanical Contracting provides:**

- ❖ **100% on time delivery of custom made equipment and machine parts.**
- ❖ **Total customer satisfaction measured by number of customer complaints and customer satisfaction survey.**
- ❖ **24 hrs on – call availability for servicing customer needs.**
- ❖ **Reduction of rework and scrap measured by job performance and non-conformance log.**

# WORLD MECHANICAL CONTRACTING INC.

## MATERIAL HANDLING SYSTEM



Specialized in the design and development of a wide range of material handling systems including sophisticated conveyor systems powered by custom built hydrostatic units

# WORLD MECHANICAL CONTRACTING INC.

## MATERIAL HANDLING SYSTEM



Tie Down Clip Assembly Line, MTI  
Peco, Toronto



Conveyor line for material, containers  
handling, circulate U shape line,  
Central Stamping, Windsor



Blank de-stacker  
Blow line\_Nartech, Guelph



Conveyor for Promo

# WORLD MECHANICAL CONTRACTING INC.

## MATERIAL HANDLING SYSTEM



320 feet long goose neck conveyor with, 270 degree rotate deflector for CEL and PMS,AL



# WORLD MECHANICAL CONTRACTING INC.

## MATERIAL HANDLING SYSTEM

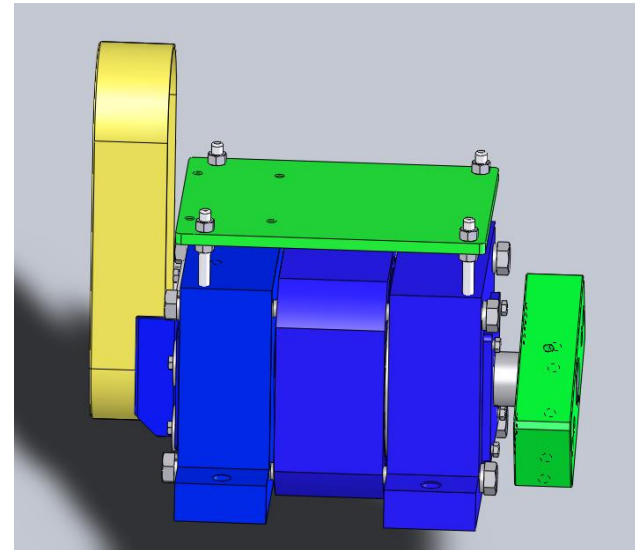
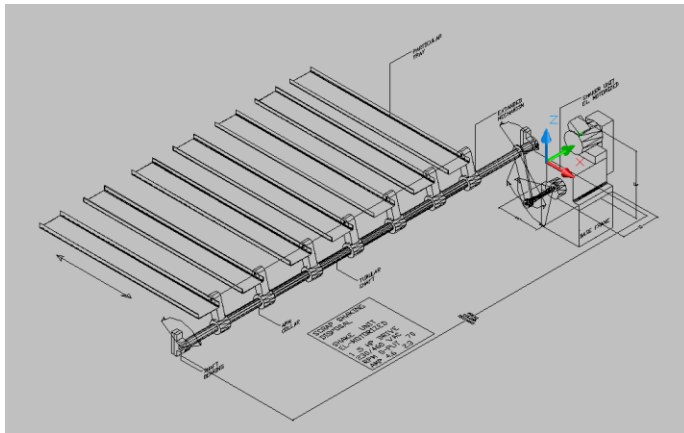

Eccenter Shaker

# WORLD MECHANICAL CONTRACTING INC.

## MATERIAL HANDLING SYSTEM



NSF-ISR

Registered  
to ISO 9001

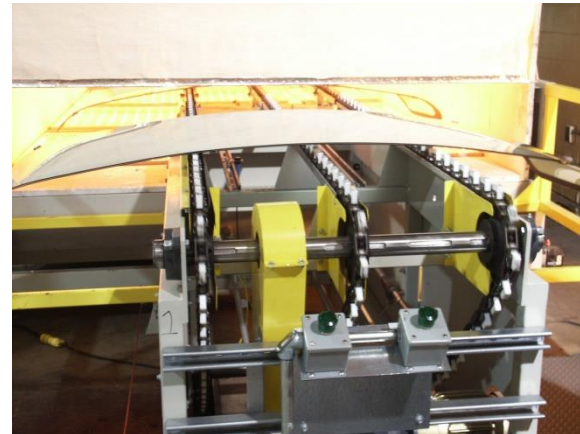

Blank De-stacker

# WORLD MECHANICAL CONTRACTING INC.

## MATERIAL HANDLING SYSTEM

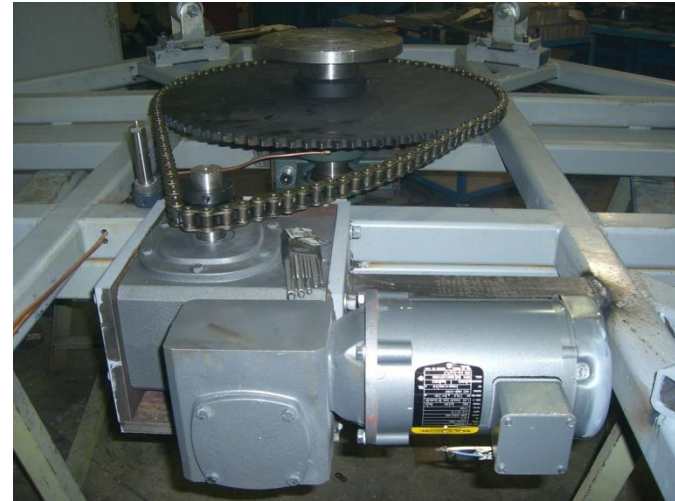

Turn Table for CSL, Windsor

# WORLD MECHANICAL CONTRACTING INC.

## MATERIAL HANDLING SYSTEM



NSF-ISR

Registered  
to ISO 9001

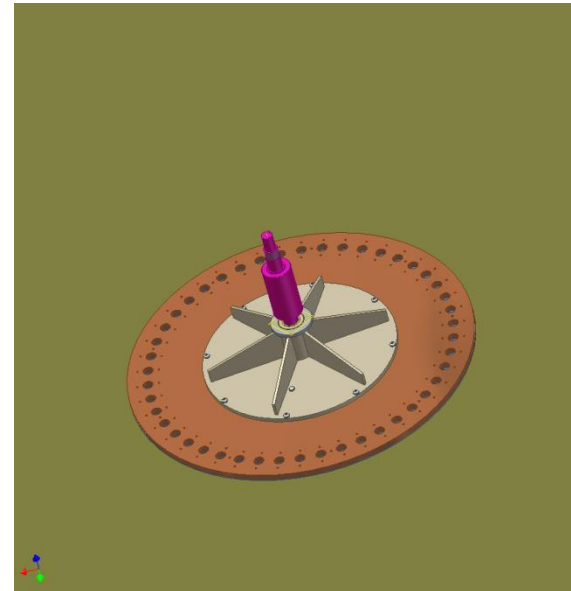
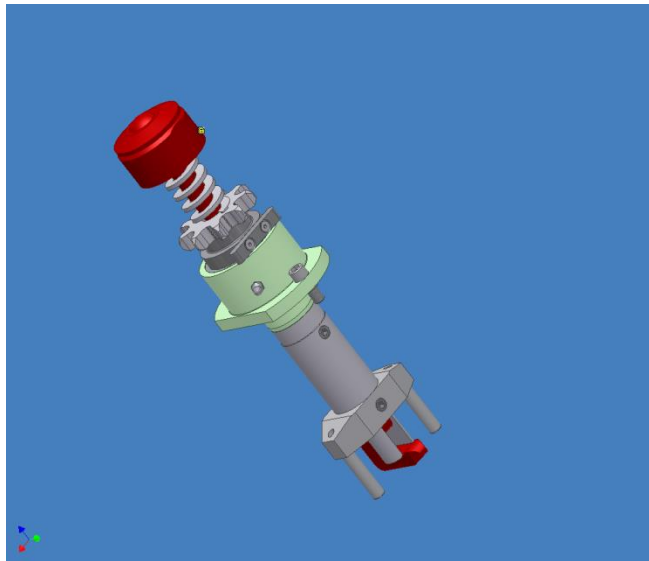

Spindle Clamp and Turn Table for GKN

# WORLD MECHANICAL CONTRACTING INC.



## FABRICATION

Large variety of WMC designed and fabricated machines, safety guarding, platforms, poke yoke tables, scissor lift tables, turn tables, HD filter conveyors, magnetic conveyors, indexing conveyors, motorized and gravity press doors, carts, steel part boxes, bolster wheels and etc....

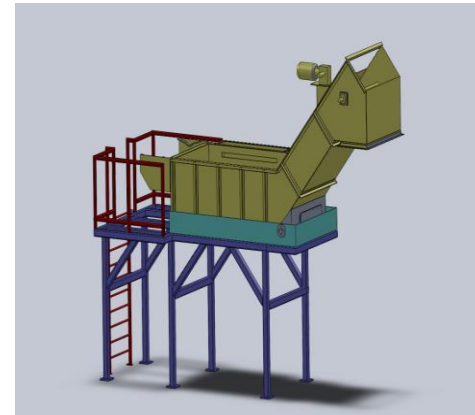
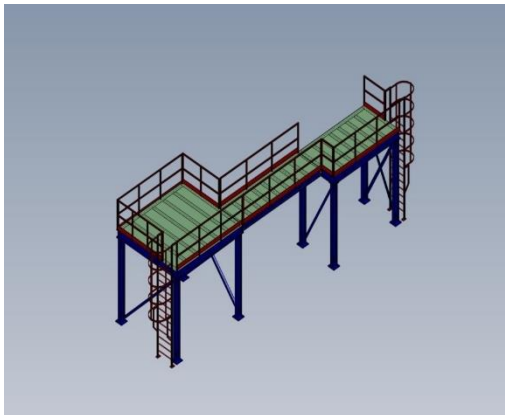

# WORLD MECHANICAL CONTRACTING INC.



NSF-ISR

Registered to ISO 9001

## FABRICATION



Motorized Door



Platform Guarding



Gravity Door

# WORLD MECHANICAL CONTRACTING INC.

## FABRICATION



Bolster and Bolster Rail



Electro Controls for  
Deflector



Coil Racks



Guarding

# WORLD MECHANICAL CONTRACTING INC.

## Green house equipment





# WORLD MECHANICAL CONTRACTING INC.

## PRESSES/ METAL FORMING

Specialized in the design, fabrication, and installation of highly sophisticated hydraulic presses and metal forming machines.



# WORLD MECHANICAL CONTRACTING INC.

## PRESSES/ METAL FORMING



NSF-ISR

Registered  
to ISO 9001



Bolster for die exchange



Hydraulic TrimPress with  
transfer table  
Haiz Lemerz  
Foundry\_Cadillac, Mich

# WORLD MECHANICAL CONTRACTING INC.

## ROBOTICS & AUTOMATION



Provides clients with turn-key automation solutions for various manufacturing processes

# WORLD MECHANICAL CONTRACTING INC.

## ROBOTICS & AUTOMATION KEY CAPABILITIES



- Installation and maintenance of press control systems (Allen Bradley, Omron and Fanuc), machine control and transfer line.
- PLC programming, testing and troubleshooting of Allen Bradley, Siemens PLC Step 7, Omron SYSWIN V 3.2A.
- Electrical designs and schematics for various machines.
- Installation, programming and maintenance of robots.
- Installation and implementation of TMS (Total Maintenance System), preventative and predictive maintenance of equipment.
- Various electrical construction (including control panels), installation and debug.

# WORLD MECHANICAL CONTRACTING INC.

## ROBOTICS & AUTOMATION

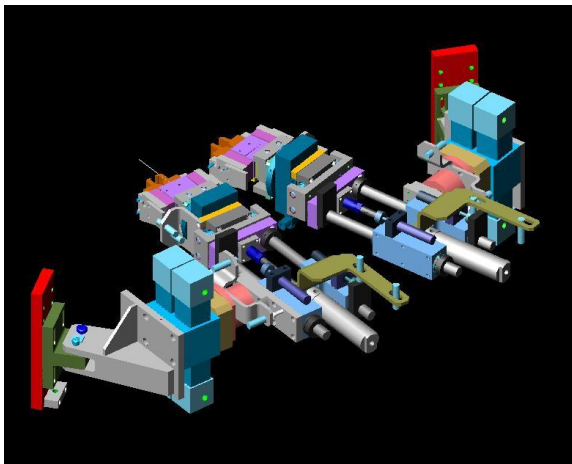

Automatic load and unload station on SPBM for GKN



Robot at welding cell RC line\_CSL, Windsor

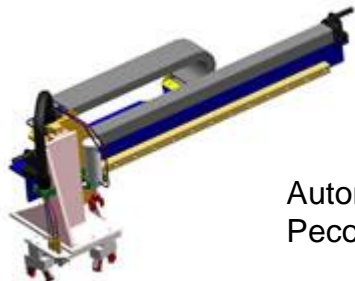

Automated Hinge Extractor, MTI Peco , Toronto



EOT of casting part after trimming process Haiz Lemez, Cadillac, Mich

# WORLD MECHANICAL CONTRACTING INC.

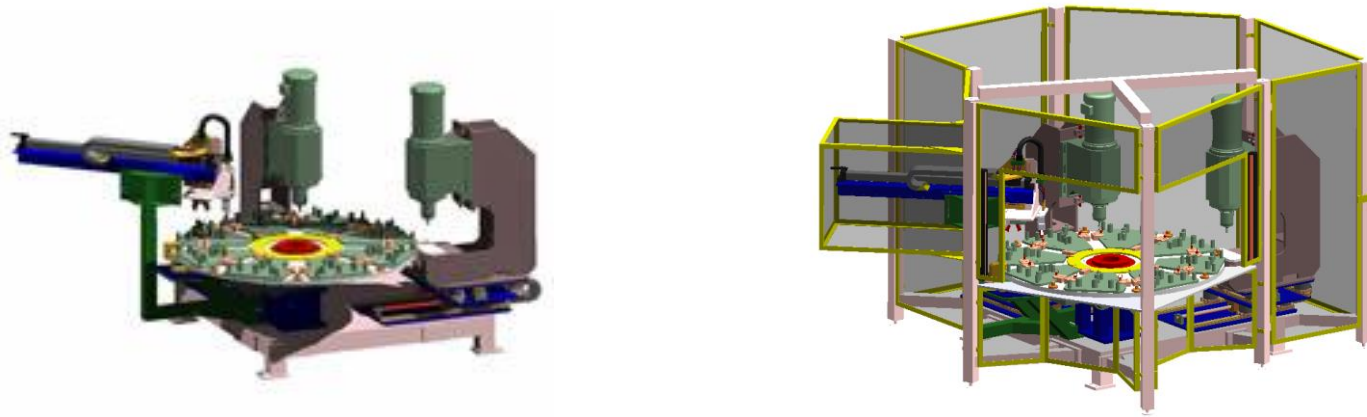

GM Hinge Fully Automated Assembly Cell, MTI Peco, Toronto.

# WORLD MECHANICAL CONTRACTING INC.



NSF-ISR

Registered  
to ISO 9001

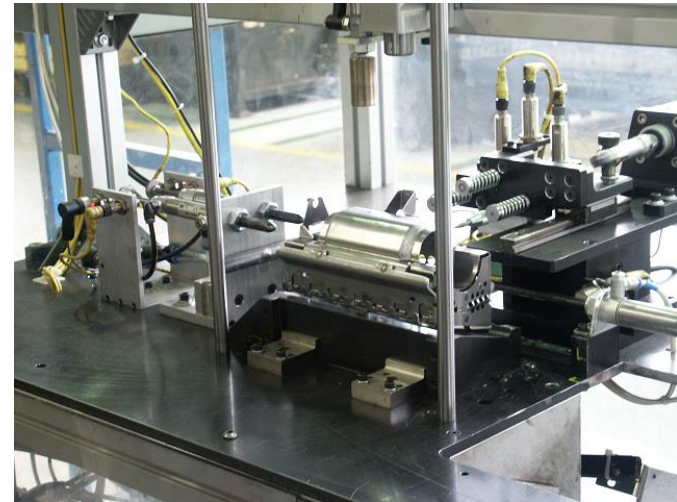
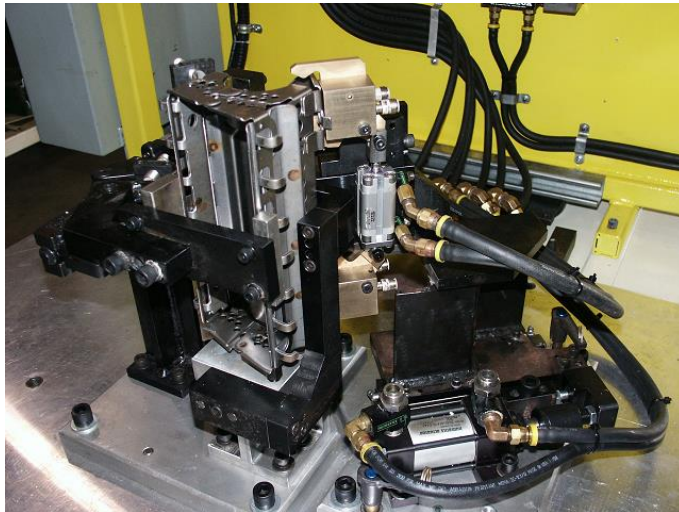

Air Bag Cage welding and assembly unit and testing machine for MTI

# WORLD MECHANICAL CONTRACTING INC.

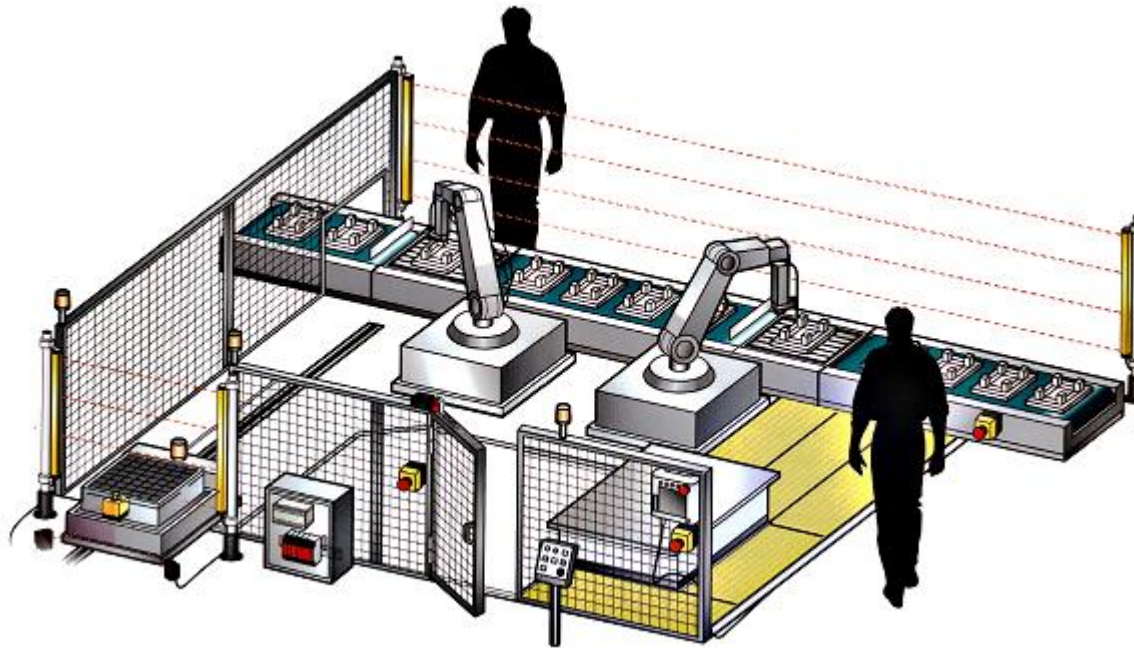

**Robot, transfer conveyor and shuttle cell for pre-assembly line in Toronto facility.**



# WORLD MECHANICAL CONTRACTING INC.



Nissan Assembly Line

# WORLD MECHANICAL CONTRACTING INC.

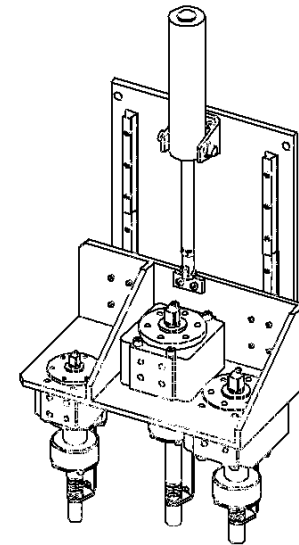
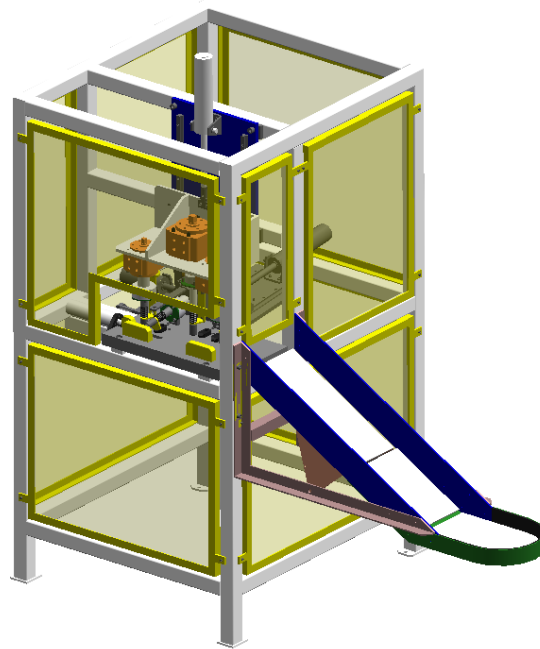

End of line nut testing machine

# WORLD MECHANICAL CONTRACTING INC.

## SCADA system for production management

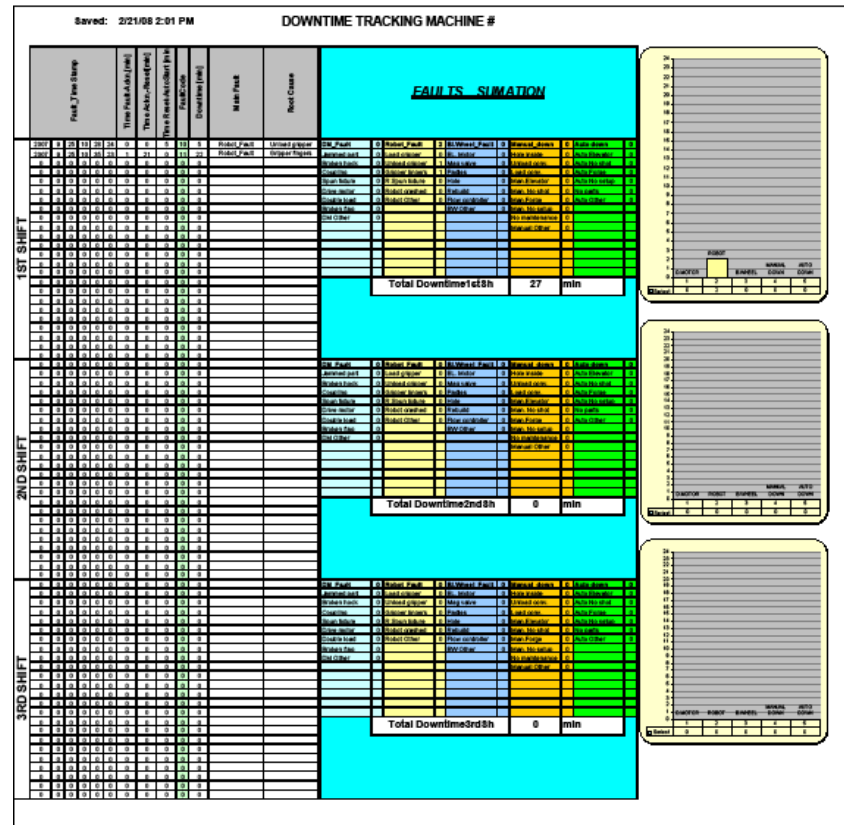

## MACHINED COMPONENTS



Provide a wide range of custom machined parts for internal equipment build requirements and external sales based on client requirements

# WORLD MECHANICAL CONTRACTING INC.



## MACHINED COMPONENTS

### Machined Parts:

Sliders

Couplings

Blocks

Mechanical connectors

Flanges

End Caps

Grippers

Block Divider

Custom Mechanical Parts

### Equipment Spare Parts

Cylinders

Pistons

Connectors

Couplers

Manifolds

All other custom mechanical

Hydraulic and pneumatic parts

# WORLD MECHANICAL CONTRACTING INC.

## MACHINED COMPONENTS

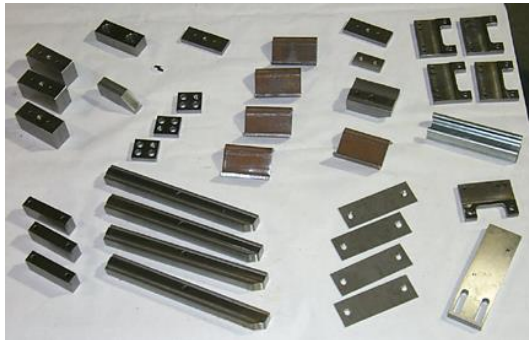

# WORLD MECHANICAL CONTRACTING INC.



NSF-ISR

Registered  
to ISO 9001

## MACHINED COMPONENTS

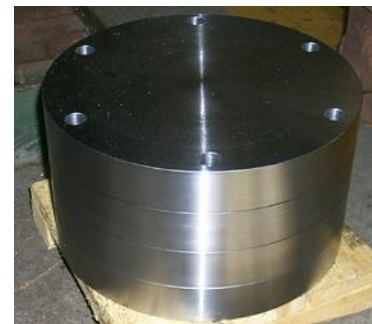
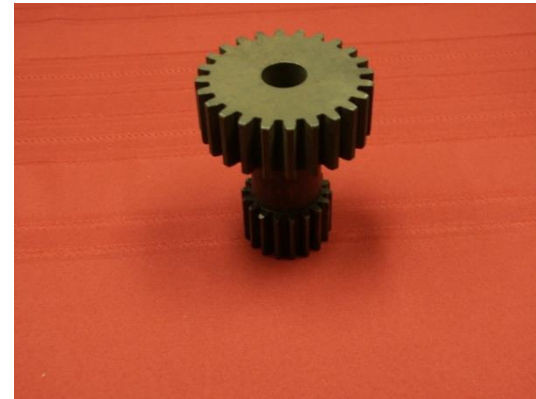

# WORLD MECHANICAL CONTRACTING INC.

## MACHINED COMPONENTS



Valiant Machine & Tool Inc. Windsor.



# WORLD MECHANICAL CONTRACTING INC.

## SERVICES



- ✓ Engineering Services
- ✓ Integration Services

# WORLD MECHANICAL CONTRACTING INC.



## ENGINEERING Key Capabilities

- Design unique custom equipment and processes based on customer requirements
- Develop customer drawings for mechanical, hydraulic and electrical circuits
- Utilization of state-of-the-art CAD, INVENTOR, CATIA, SOLID EDGE, SOLID WORKS to expedite the design and proof of concept process

# WORLD MECHANICAL CONTRACTING INC.



- ENGINEERING

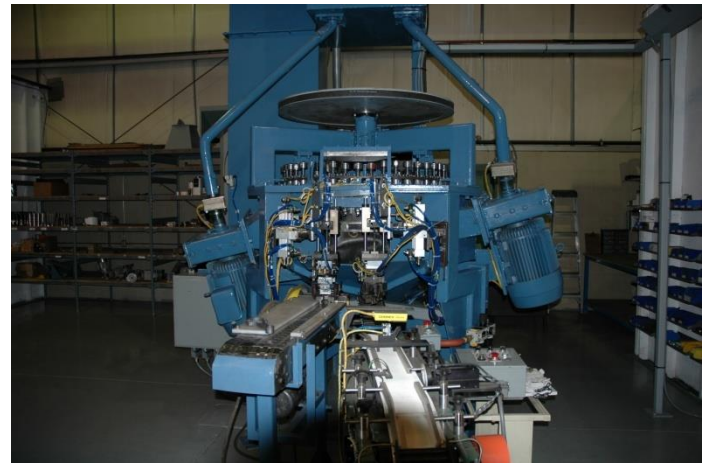
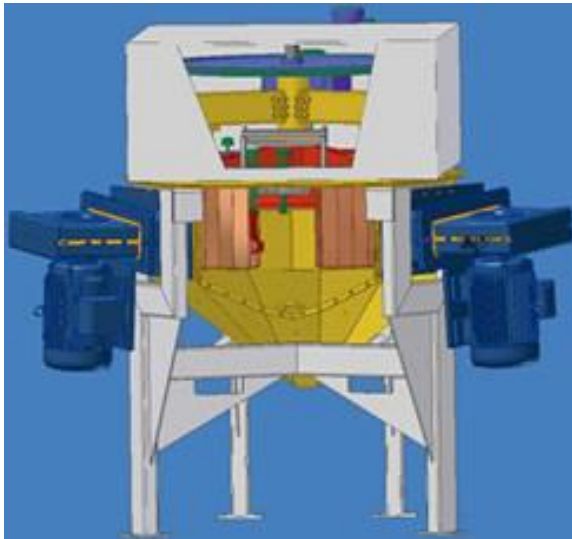

INLINE DEDICATED SHOT PEEN BLASTING  
MACHINE FOR GKN SINTER METALS

# WORLD MECHANICAL CONTRACTING INC.

## INTEGRATION SERVICES

### Key Capabilities



- Design processes and controls.
- Manufacture, program and assemble system components.
- Integrate communications, wiring, hydraulics and pneumatics

# WORLD MECHANICAL CONTRACTING INC.



## • CUSTOMERS

- NARMCO GROUP WINDSOR, CANADA
- CROSS HULLER MI, USA
- FALCON TOOL & DIE WINDSOR, CANADA
- GKN SINTER METALS MI, USA
- KAUTEX CORPORATION WINDSOR, CANADA
- NARTECH METAL PRODUCTS GUELPH, CANADA
- SHULLER – PRESS CLINTON, USA
- SIEMENS VDO LONDON, CANADA
- ZETTEL MANUFACTURING INC. KITCHENER, CANADA
- HAYES LEMMERZ INTERNATIONAL INC. MI, USA
- GENERAL AUTO WINDSOR, CANADA
- MTI-PECO INC. CANADA
- PRINCE METAL STAMPING AL, USA
- VALIANT MACHINE & TOOL INC. WINDSOR, CANADA

# WORLD MECHANICAL CONTRACTING INC.

## REFERENCE



COMPANY NAME	CONTACT PERSON	TITLE	TELEPHONE
NARMCO GROUP	MIKE APOLLONIO	CORPORAE CAPITAL PROJECT MANAGER	(519) 737-1361X225
CENTRAL STAMPING LTD.	TONY TURTON	CORPORATE MANUFACTURING MANAGER	(519) 945-1111X1247
WECON SYSTEMS LTD.	LAZA RADOCAJ	PROJECT MANAGER	(905) 624-6499X236
J.F.K. SYSTEMS INC.	DARCY GADHOURY	DESIGNER CAPITOL PROJECTS	(519) 737-1361X244
GKN SINTER METALS	BRANKO CVETKOVIC	PROCESS DEVELOPMENT MANAGER	(519) 965-7034
SIEMENS VDO	SAM VALO	STRATEGIC BUYER	(519) 682-5115
CROSS HULLER	SANTE FORTIN	EXPEDITER	(586) 532-3038
KAUTEX CORPOTATION	MARKUS LABUSCH	MANUFACTURING ENGINEER	(519) 251-7603
SHULLER-PRESS	KLAUS HERTELL	ENGINEERING MANAGER	(734) 207-7263
SCHUKRA OF N.A.	SRIDHAR RAO	BUYER	(519) 727-7000X1928
RUSSELL TOOL & DIE LTD.	RON VANNIEUWENHUYZE	GENERAL MANAGER	(519) 352-8169
JNM TOOL & MANUFACTURE INC / WMT	LAZA RADOCAJ	PROJECT MANAGER	(905) 624-6499X236
INTEGRAM	JOE MAMMORELLA	PROJECT MANAGER	(226) 229-0749